



MS6 Series AC Servo Motors
Safety User Manual

Wuxi Xinje Electric Co., Ltd.

Reference number: MSC 01 20250617 1.1

	Catalog	
	Product confirmation	1
	Environmental requirements	2
AC servo motor	Motor installation requirements	3
Safety Manual	Cable installation requirements	4
	Brake explanation	5
	High power motor	6
	Fluid-cooled electrical machine	7
	Manual update log	

Basic Description

- Thank you for purchasing the Xinje servo motor.
- This manual mainly introduces the safe use instructions of servo motor.
- Before using the product, read this manual carefully and install and connect the wiring only after fully understanding its contents.
- Please deliver this manual to the end user.

This manual is intended for the following users

- Servo system designer
- Installation and wiring workers
- Trial run and debugging worker
- Maintenance and inspection worker

Access to the manual

- Electronic Manual
Visit Xinje's official website at www.xinje.com to download.

Statement of responsibility

- The contents of the manual have been carefully checked, but errors are inevitable, and we cannot guarantee complete consistency.
- We will review the manual regularly and make corrections in future versions. Your feedback is welcome.
- If there are any changes to the content in the manual, please understand that no separate notice will be given.

Contact way

For any questions about using this product, please contact the purchasing agent or office, or directly reach out to Xinje Company.

- Switchboard: 0510-85134136
- Hotline: 400-885-0136
- Website: www.xinje.com
- Email: xinje@xinje.com
- Address: No.816, West Jianzhu Road, Binhu District, Wuxi City, Jiangsu Province

Wuxi Xinje Electric Co., Ltd. Copyright

No reproduction, distribution, or use of this material and its contents is permitted without explicit written authorization. Violators shall be held liable for any resulting damages. All rights, including those related to patents and registrations for utility modules or designs, are reserved.

March 2025

Safety Precautions

Before using our company's servo motor, please read this manual carefully and operate only after fully understanding the product's usage, safety, and precautions. Install and use the servo motor strictly according to the manual instructions.

This manual outlines potential issues during product use, categorized into three risk levels: 'Caution', 'Danger', and 'Prohibited'. For any other matters, please strictly follow the basic electrical operating procedures.



Note

Improper use may cause danger, personal safety threat, and motor damage.



Danger

Improper use may result in dangerous situations, causing personal injury or death, serious harm, and potentially significant property damage.



Prohibit

This operation is prohibited. It may damage the device and cause serious personal injury.



Matters need attention

1. For clarity, some illustrations in this manual omit the motor casing or other components. During actual operation, ensure the motor remains intact, avoid unauthorized disassembly of the casing, and install it in the designated position as specified.
2. The illustrations in this booklet are representative examples and may differ from the motor you purchased. Unless otherwise specified, they are consistent with the descriptions in the representative examples.
3. Our company provides no quality guarantee for motors modified by customers without authorization. We shall not be liable for any damages or losses resulting from such unauthorized modifications.

Catalog

CATALOG	ii
►► CONFIRMATION UPON PRODUCT DELIVERY	1
1 PRODUCT CONFIRMATION	2
1.1 INTRODUCTION TO MOTOR NAMEPLATE	2
1.2 SECTION DESCRIPTION	2
2 ENVIRONMENTAL REQUIREMENTS	3
2.1 SERVICE ENVIRONMENT	3
2.2 HEAT RADIATION	4
2.2.1 Heat dissipation installation diagram	4
2.2.2 Heat sink size	4
3 MOTOR INSTALLATION REQUIREMENTS	5
3.1 MOTOR BODY INSTALLATION REQUIREMENTS	5
3.2 SERVO MOTOR AND MECHANICAL INSTALLATION	6
3.2.1 Installation of Coupling	6
3.2.2 Installation of synchronous belt	7
3.2.3 Installation of shaft and key	7
3.3 AXIAL LOAD, RADIAL LOAD SPECIFICATION	9
3.4 SHAFT EXTENSION AND KEY SIZE	9
3.5 OIL-WATER POLICY	10
4 CABLE INSTALLATION REQUIREMENTS	11
5 BRAKE EXPLANATION	13
5.1 SPECIFICATIONS OF BRAKE FOR MOTOR SERIES	13
5.2 POWER-OFF BRAKE WIRING (BRAKE ENGAGEMENT)	14
5.3 FALSE TRIP OF BRAKE	15
6 HIGH POWER MOTOR	16
6.1 DESCRIPTION OF THE PARTS OF HIGH POWER MOTOR	16
6.2 INSTALLATION OF HIGH POWER MOTOR	16
6.3 ELECTRIC FAN	17
6.3.1 Fan specifications	17
6.3.2 Fan wiring	17
6.3.3 Fan Cooling Precautions	18
7 FLUID-COOLED ELECTRICAL MACHINE	19
MANUAL UPDATE LOG	20

►► Confirmation upon product delivery

After the product arrives, please check its condition in the following aspects.

Confirm item	Remarks
Is the delivered product the same as the model you ordered?	Refer to the motor nameplate for confirmation.
Is there any broken part?	Examine the exterior for any damage caused by transportation or similar factors.
Is there any loose screw?	Check for any looseness with a screwdriver.

If any issues are found with the listed items, please contact the product's agent, office, or Xinje Company's sales department promptly.

1 Product confirmation

1.1 Introduction to Motor Nameplate

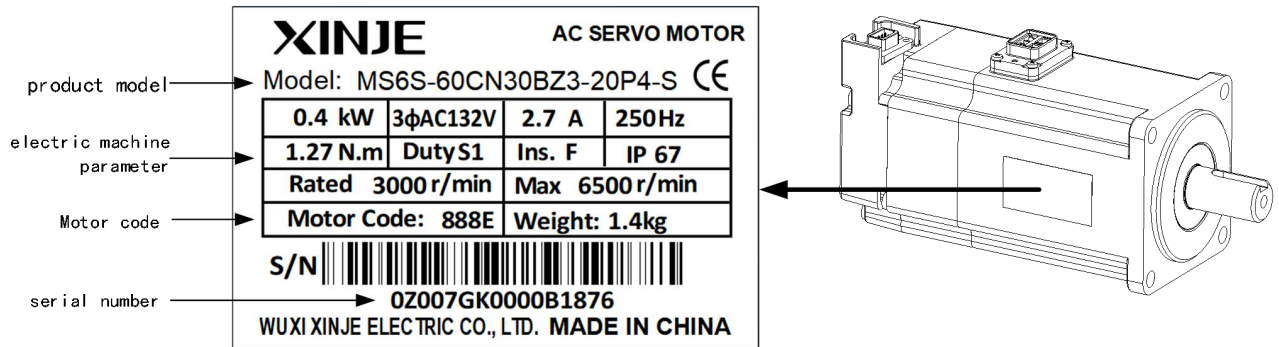

1.2 Section Description

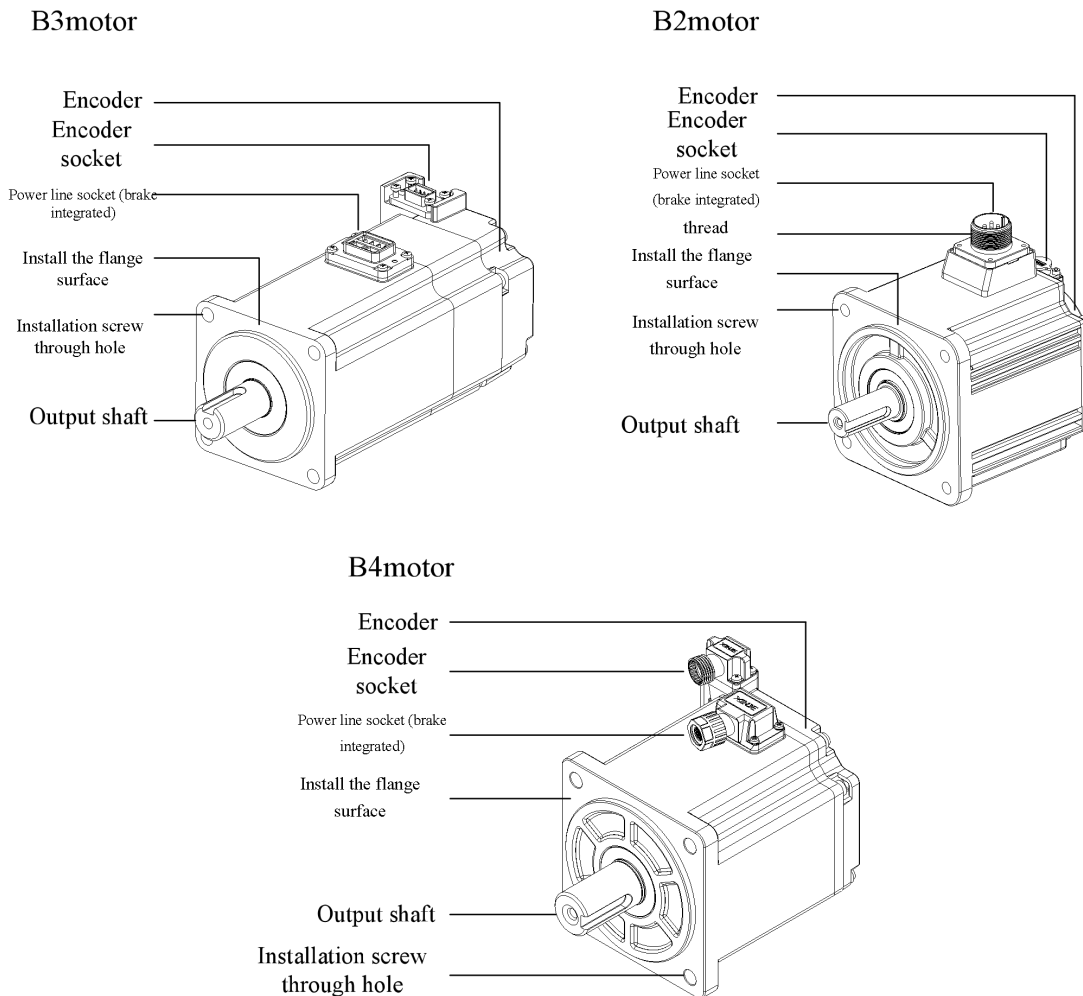

2 Environmental requirements

2.1 service environment

Project	Description
Ambient temperature	-10~40°C (no condensation)
Environmental humidity	20~90% rh (no condensation)
Storage temperature	-20~60°C (maximum temperature guaranteed: 80°C for 72 hours)
Storage humidity	20~90% rh (no condensation)
Vibration resistance (Acceleration of vibration)	Radial: 49 m/s ² Axial: 24.5 m/s ²
Impact resistance	98 m/s ² impact times: 2
Above sea level	Do not exceed 1000m. For heights above 1000m, apply a 1% reduction in capacity (every 100m increase).
Cooling-down method	Air cooling / liquid cooling / natural cooling
Levels of protection	Ip67/ip66/ip65/ip54 (check the motor's nameplate for specific model)



- The vibration intensity applied to the servo motor varies depending on the application. Always verify the vibration acceleration through the actual product.
 - To achieve the above protection level, the motor and the matching cable must be correctly inserted and locked.
-

2.2 Heat radiation

2.2.1 Heat dissipation installation diagram

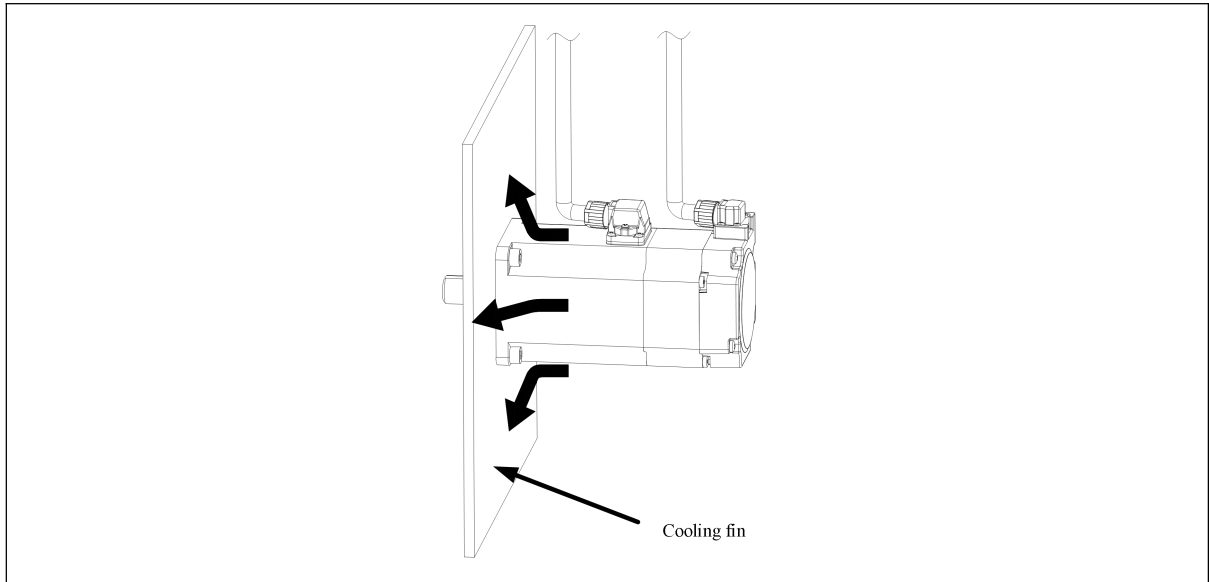

- The heat generated by the servo motor is transferred to the mounting side via the motor flange and dissipated through the heat sink.
- Avoid using insulators like gaskets between the servo motor and heat sink to prevent motor overheating and potential failure.
- The normal human hand can tolerate a temperature range below 43°C, and brief exposure to 50°C (1 second) will trigger a hand-shrinking response.

2.2.2 Heat sink size

Power of motor(kw)	Heat dissipation plate length (mm)	Heat dissipation plate width (mm)	Heat dissipation plate thickness (mm)
≤0.75	250	250	6
0.85~2.6	400	400	20
2.9~5.5	550	550	30
7.5	700	700	30



The above dimensions are recommended values. The motor's heat output varies under different operating conditions, so the heat sink size can be adjusted according to actual needs.

3 Motor installation requirements

3.1 Motor Body Installation Requirements

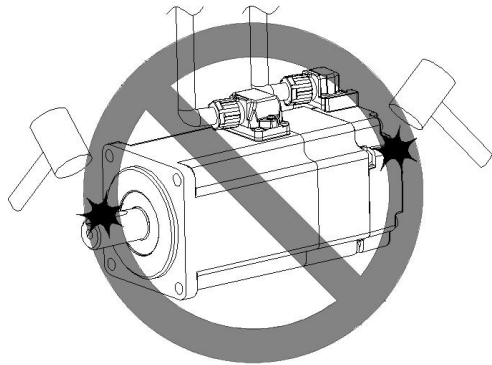
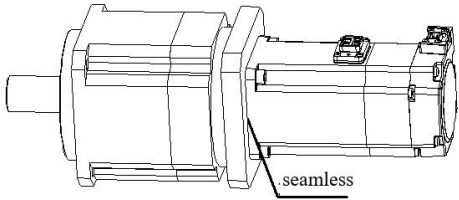
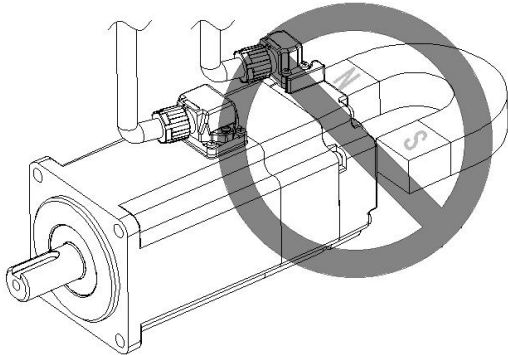
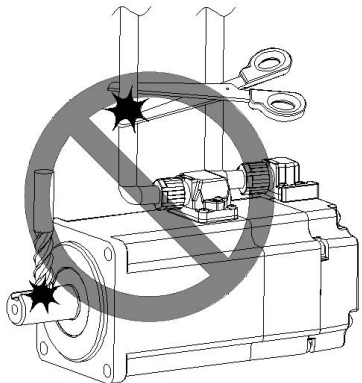
	
<p>Do not use a hammer or other tools to strike the shaft or the back cover of the encoder to avoid damaging the internal motor structure.</p>	<p>When installing a servo motor via a flange, ensure there is no gap between the flange and the reducer.</p>
	
<p>As the servo motor contains an absolute encoder with built-in magnetic sensors, avoid placing strong magnetic devices near it to prevent encoder damage or operational interference.</p>	<p>Do not process this product yourself to avoid unnecessary equipment and personnel injuries.</p>

3.2 Servo Motor and Mechanical Installation

3.2.1 Installation of Coupling

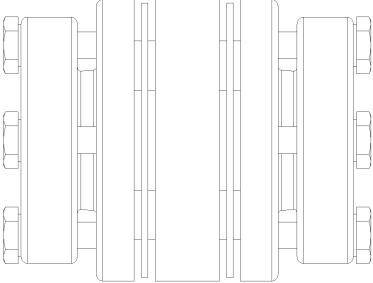
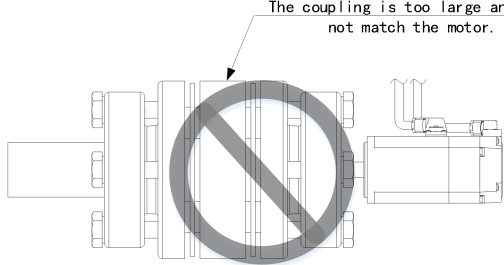
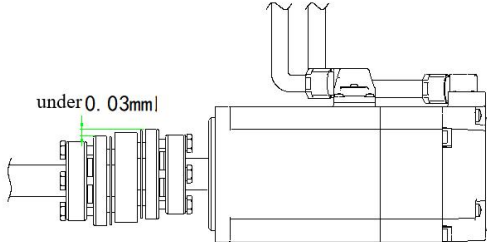
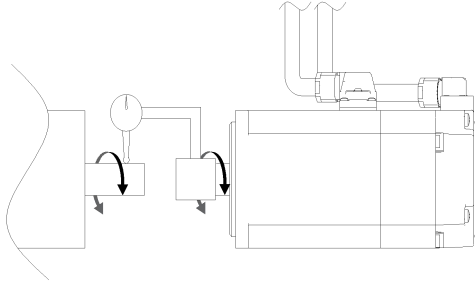
	
<p>It is recommended to use a flexible coupling for servo motor.</p>	<p>It is recommended to use a coupling of appropriate size to prevent malfunctions.</p>
	
<p>Ensure the coupling centering precision during installation is $\leq 0.03\text{mm}$ and optimize it as much as possible. If the coupling produces abnormal noise, readjust until the sound disappears.</p>	<p>During core alignment, install a dial indicator on the coupling to measure radial and axial deviations, or use a laser centering instrument for high-precision measurement. If these conditions are not met, manually rotate the coupling to check for smooth operation. If there is noticeable jamming or vibration, readjust the alignment. Manual core alignment can meet the operational requirements of most equipment.</p>

3.2.2 Installation of synchronous belt

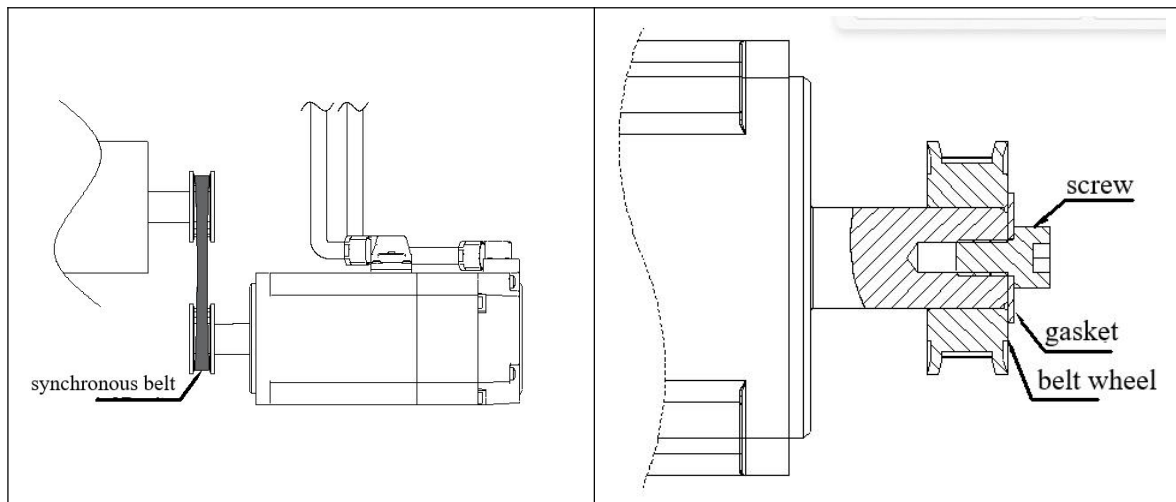

- Select the appropriate synchronous belt based on the servo motor's allowable radial load and output power.
- When installing the synchronous belt, ensure its tension is lower than the shaft's radial load capacity (see Section 3.3 for axial and radial load specifications), and allow for the tension generated during acceleration and deceleration.
- When installing pulleys on a servo motor, first verify that all components—such as the servo motor, pulley, washers, and screws—are intact and properly assembled, and prepare necessary tools (e.g., wrenches). Align the pulley's shaft hole with the motor shaft and move it steadily to ensure concentricity. Then, install a properly sized washer on the motor shaft to compensate for misalignment, enhance friction, and prevent loosening. Finally, insert the screws into the threaded holes to gradually secure the washer onto the pulley, ensuring reliable fixation.
- When removing the pulley, use a pulley remover to prevent the bearing from being subjected to strong impact loads.
- To ensure safety, install a protective cover or similar device in the rotating area.

3.2.3 Installation of shaft and key

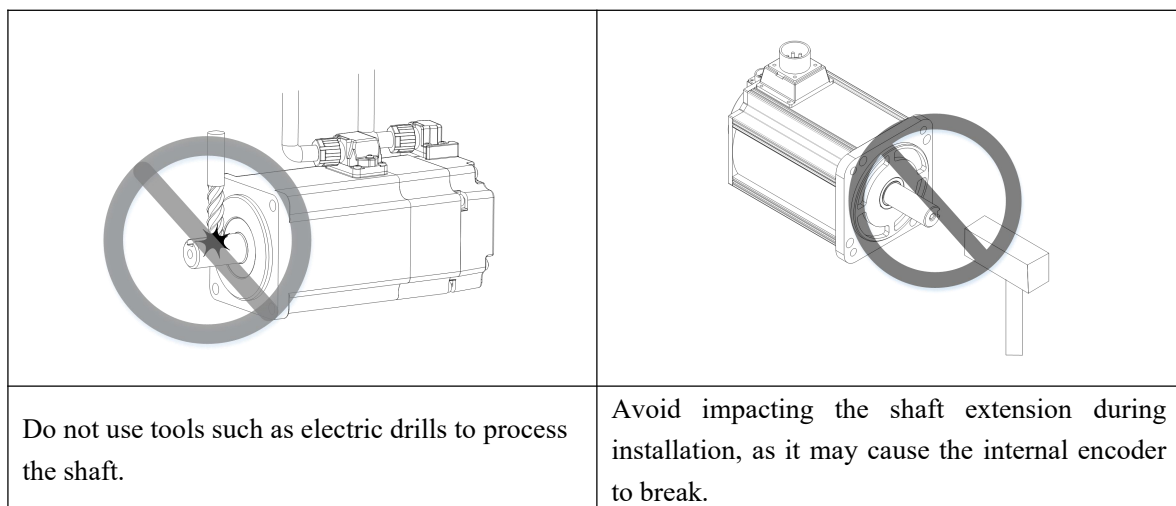

Do not use tools such as electric drills to process the shaft.

Avoid impacting the shaft extension during installation, as it may cause the internal encoder to break.

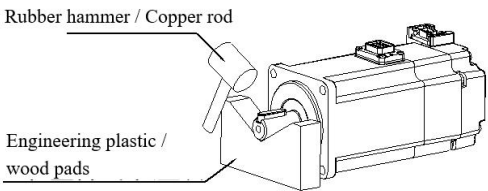
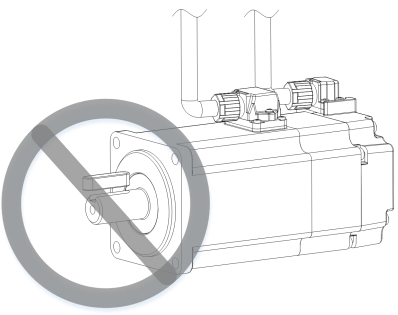
 <p>Rubber hammer / Copper rod</p> <p>Engineering plastic / wood pads</p>	
<p>Install the key correctly. Do not use a hammer to tap the shaft key without proper protection.</p>	<p>Use the key provided with the product or one that matches the size specified in the manual. Do not install a key that does not fit the keyway.</p>

3.3 Axial load, radial load specification

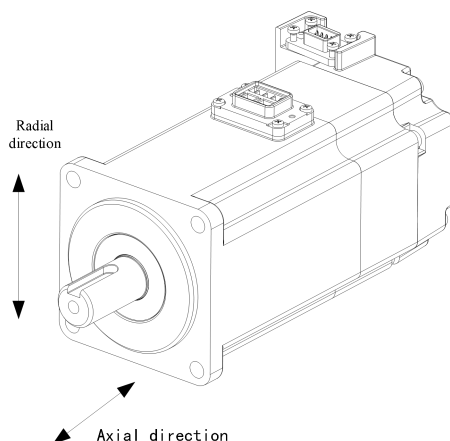

Seat no	40	60	80	100	110	130	180	200	220	265
Axial loading	54N	74N	147N	196N	147N	196N	400N	640N	686N	1120N
Radial load	78N	245N	392N	500N	392N	686N	800N	1880N	2254N	3200N



When using, avoid exceeding the specified axial and radial load limits, as this may cause motor failure and pose a hazard.

3.4 Shaft extension and key size

Product line	Seat no	Shaft extension dimension (including boss) (unit : mm)	Shaft keyway dimension (unit : mm)	Standard keyboard specifications (unit : mm)
MS6L	100	45	8×4×32	8×7×32
MS6S	60	30	5×3×20	5×5×17
	80	35	6×3.5×25	6×6×24
	100	45	8×4×32	8×7×32
	130	63	8×4×54	8×7×53
MS6G	110	55	6×3.5×42.5	6×6×39
	130	55	8×4×40	8×7×40
	180	79 (Other 180 motor bases)	10×5×66	10×8×65
		113 (5.5kW, 7.5kW B2 motor)	12×5×96	12×8×96
200	82	12×5×56	12×8×56	
MS6H	40	25	3×1.8×15	3×3×13.5
	60	30	5×3×20	5×5×17
	80	35	6×3.5×25	6×6×24
	130	57	8×4×40	8×7×40
	180	79 (Other 180 motor bases)	10×5×65	10×8×65

Product line	Seat no	Shaft extension dimension (including boss) (unit : mm)	Shaft keyway dimension (unit : mm)	Standard keyboard specifications (unit : mm)
		113 (5.5kW, 7.5kW B2 motor)	12×5×96	12×8×96
MS5	110	55	6×3.5×40	6×6×39
	130	57	6×3.5×40	6×6×39
	220	116	12×5×90	12×8×89

3.5 Oil-water policy

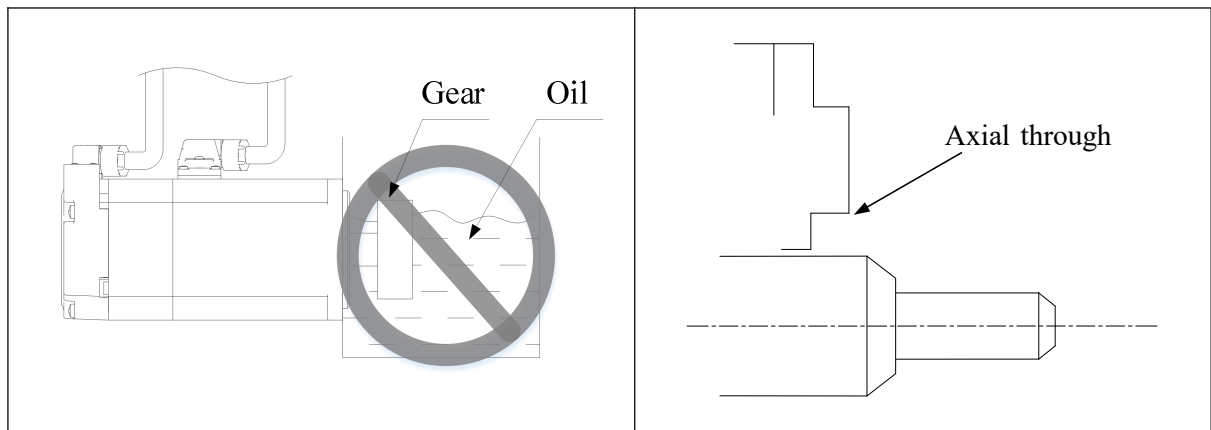

- If the installation environment poses a water droplet risk (excluding the motor shaft end), verify whether the motor's main protection rating meets operational requirements.
- If the motor shaft penetration part may contact oil splash, the servo motor with oil seal must be selected.
- Oil seals come with lubricating grease at the factory. They should be replaced after 5000 hours of normal operation.
- Maintain proper lubrication for the oil seal. Under normal operation, it only protects against oil splashes. Never submerge the oil seal below the oil level, as this may cause oil to enter the servo motor and lead to malfunction.
- Regularly inspect the reducer oil for leaks to prevent it from overflowing the motor's oil seal lip and causing oil ingress.
- When installing the servo motor vertically, ensure the oil seal lip does not accumulate oil.
- Do not install the servo motor in areas where it may come into contact with cutting fluid, as this could damage the oil seal, cables, or other components.
- If it is unavoidable to use in an environment with chip fluid, take measures outside the servo motor to prevent oil and water vapor from entering.

4 Cable installation requirements

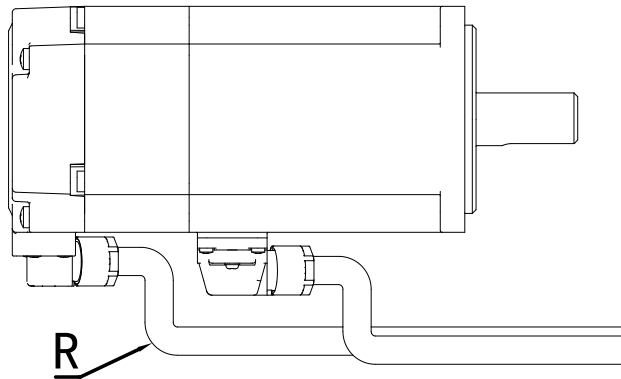

Cable type	Cable performance specification		Cable installation specifications	
	Temperature resistance	Withstand voltage	Fixed installation	Mobile installation
Regular cable	-20°C~80°C	2000V/min	≥5*D	/
High-flex cable	-20°C~80°C	2000V/min		If the travel distance is ≤2 meters and $R \geq 7.5*D$, then the $N \geq 3$ million times; If the travel distance is ≤2 meters and $R \geq 10*D$, then the $N \geq 5$ million times;

Note: D denotes the finished wire diameter, R the bending radius, and N the number of bending cycles.



High-flexible cable is recommended for bending scenarios.

<p>Do not perform wiring work while the circuit is energized.</p>	<p>Use the connector specified by our company and connect it correctly.</p>

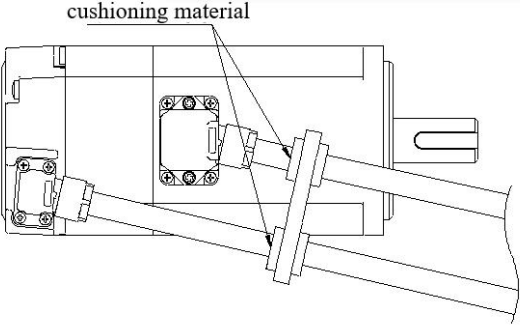
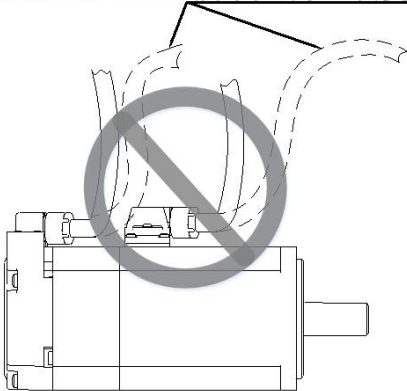
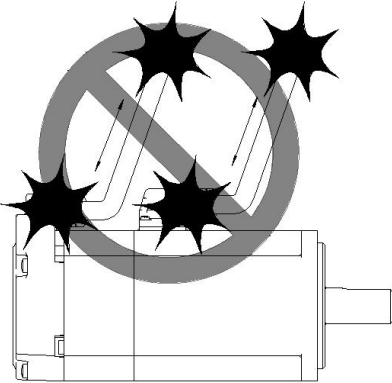
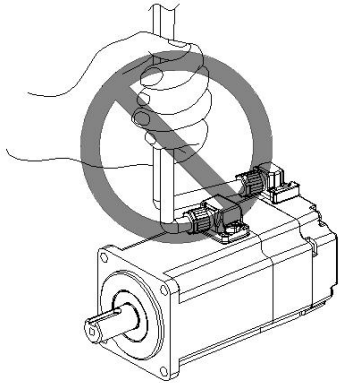
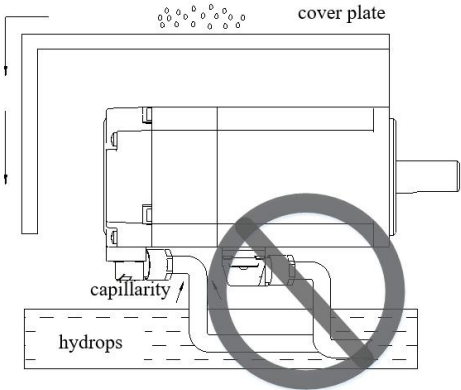
	<p>Non-flexible cables are prohibited from being repeatedly bent.</p> 
<p>When bundling encoder wires with power lines, use protective materials to shield the cables from damage, which could otherwise shorten the equipment's lifespan.</p>	<p>For encoder and power cables that are not high-flex or high-flex oil-resistant types, it is recommended to use them in fixed installation environments and avoid repeated bending.</p>
	
<p>When plugging or unplugging power lines and encoder terminals, avoid excessive force.</p>	<p>When handling the cable while it remains connected, always hold the servo motor body. Grabbing only the cable may damage the connector or break the cable.</p>
	
<ul style="list-style-type: none"> ● Do not use cables by immersing them in liquids such as oil or water. ● If oil and water splashing cannot be avoided due to environmental conditions, use oil-resistant cables. ● When installing motors in liquid-containing environments, position the motor's wiring terminals downward to prevent liquid from flowing into the motor through the cables. ● When installing the motor with the shaft end facing upward, avoid using it in environments where oil, water, or servo motor contact occurs. 	

5 brake explanation

5.1 Specifications of Brake for Motor Series

Product Series	Seat no	Static friction torque (N.m)	Power rating (W)	Exciting current (A)	Pickup voltage (V)	Exciting voltage (V)
MS6L	100	≥10	17.6	0.73	≤16.8	DC24V (±10%)
MS6S	60	≥1.3	7.4	0.308	≤16.8	
	80	≥3.2	11.5	0.48	≤16.8	
	100	≥8	17.6	0.733	≤16.8	
	130 (3kW)	≥15	16.9	0.705	≤16.8	
	130 (5kW、7kW)	≥23.5	23	0.945	≤16.8	
MS6G	110	≥6	18	0.75	≤16.8	
	130	≥15	16.9	0.705	≤16.8	
	180	≥55	31	1.291	≤16.8	
	200	≥150	61	2.539	≤19.2	
MS6H	40(50W)	≥0.32	6.1	0.254	≤16.8	
	40(100W)	≥0.32	6.1	0.254	≤16.8	
	60	≥1.3	7.4	0.308	≤16.8	
	80	≥3.2	11.5	0.48	≤16.8	
	130	≥15	23	0.96	< 18	
	180	≥58	30	1.25	≤16.8	
MS5	110	≥8	14.4	0.6	≤16.8	
	130	≥15	23	0.96	< 18	
	220	≥150	88	3.66	≤16.8	



- The static friction torque of the brake is affected by the actual working temperature of the motor, and the actual performance of the brake will be affected by the temperature being too high or too low.
- The above electrical parameters were tested at 20°C ambient temperature during factory testing.

5.2 Power-off brake wiring (Brake engagement)

- Brake motor with power of 400W or less (brake current <400mA)

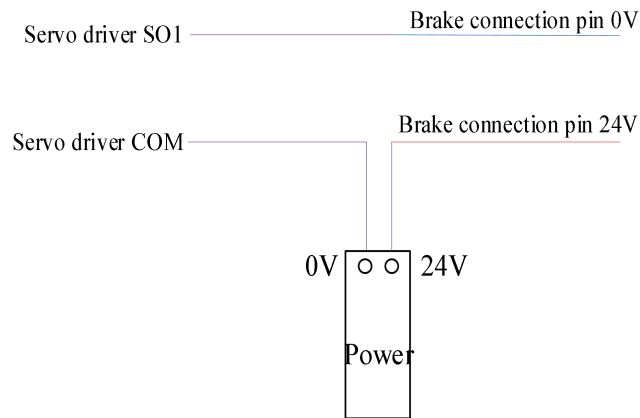

- When the motor brake current is below 400mA, the brake can be controlled via the SO1 point of the servo driver, with brake parameter P5-44 set to n.0001 to prevent terminal burnout from excessive current or brake failure due to inability to open.
- The brake must not share the power supply with other electrical devices to prevent voltage or current reduction caused by other devices, which may trigger false operation of the brake.
- The length of motor brake cable should be designed to account for the voltage drop caused by cable resistance, and the operating input voltage of the brake should be maintained between 24 and 26 volts.
- The power-off brake is designed to maintain braking and should not be used for emergency braking or equipment shutdown.

- Brake motor with power exceeding 400W (brake current >400mA)

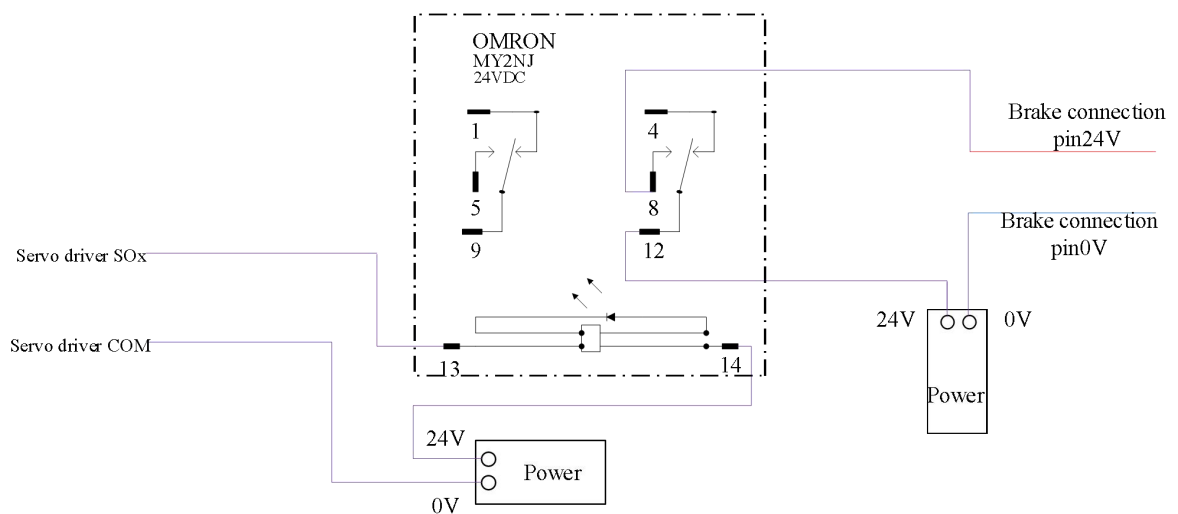



- When the motor brake current exceeds 400mA, an intermediate relay must be used for switching, and the brake parameter P5-44 should be set to n.000□ according to the connected SO terminal. This prevents terminal burnout from excessive current or brake failure due to inability to open.
 - It is recommended that the SO terminal and the intermediate relay should not share the same switch power supply.
 - The brake must not share the power supply with other electrical devices to prevent voltage or current reduction caused by other devices, which may trigger false operation of the brake.
 - The length of motor brake cable should be considered fully to the voltage drop caused by the cable resistance, and the working input voltage of brake should be 24~26V.
 - The power-off brake is designed to maintain braking and should not be used for emergency braking or equipment shutdown.
-

5.3 False trip of brake

■ Brake overheating

Even when the servo motor is not in operation, the power-off brake (in the open state) will generate heat.

Under normal operation, a motor temperature below 100°C won't affect its hardware or performance. You can use it with confidence.

■ Brake rotation clearance

The power-off brake (brake lock) maintains minimal rotational clearance ($\leq 1.5^\circ$ under 20% rated torque test) on the output shaft even in the locked position, with no brake malfunctions observed.

■ The brake pads make a screeching sound.

When the brake motor is running, the brake may occasionally make a creaking or rattling sound. This is caused by the structure of the brake module, not a malfunction, and will not affect the motor's functionality.

6 High power motor

6.1 Description of the Parts of High Power Motor

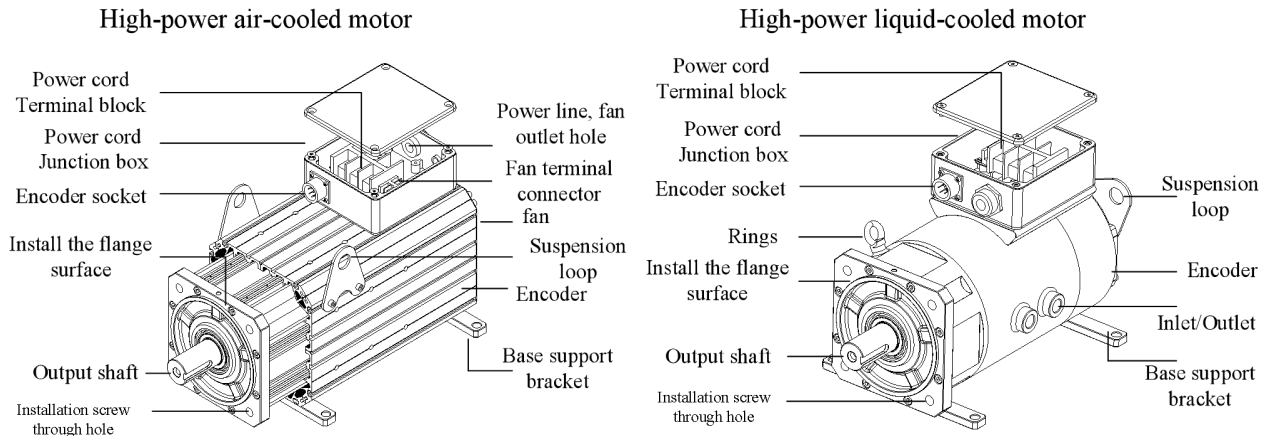

6.2 Installation of High Power Motor

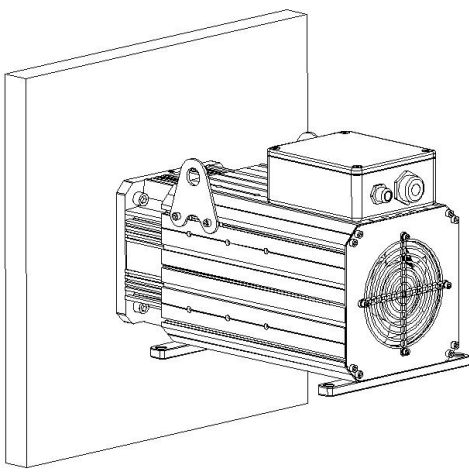
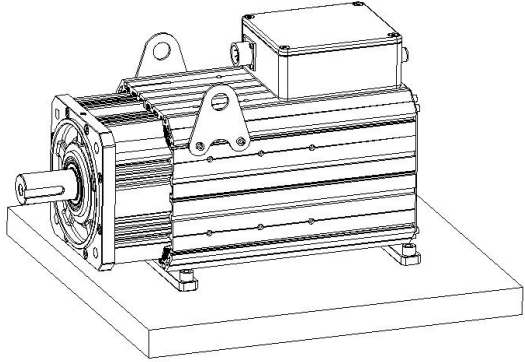
	
<p>Flange mounting</p>	<p>Footing installation</p>
<ul style="list-style-type: none"> ● When installing flange surfaces, ensure they are perfectly aligned with the connecting equipment, maintaining parallel alignment without gaps, and tighten all bolts securely. ● For corner installation, ensure the motor base is level and free of foreign objects, oil stains, or other debris. ● When tightening the bolts, use a cross-tightening method step by step to ensure even force distribution between the base angle and the motor's bottom, ensuring a secure connection. ● After installation, run a test to check the motor's vibration and noise levels, ensuring proper installation. 	

6.3 Electric fan

6.3.1 Fan specifications

Fan material code	Any power-generating or power-driven machine Power (kw)	Motor base	Voltage (v)	Frequency (hz)	Number of phases	Import Power (w)	Current (a)	Speed (r/min)	Noise (db)	Weight (kg)
1228010008	13/17/21/27	200	220	50	1	38	0.25	3000±10 %	60.9	0.7
1228010013	30~75	265	220	50	1	73	0.332	280±10 %	69	/
1228010007	45	265	220	50	1	134	0.65	2600	65	2.5

6.3.2 Fan wiring

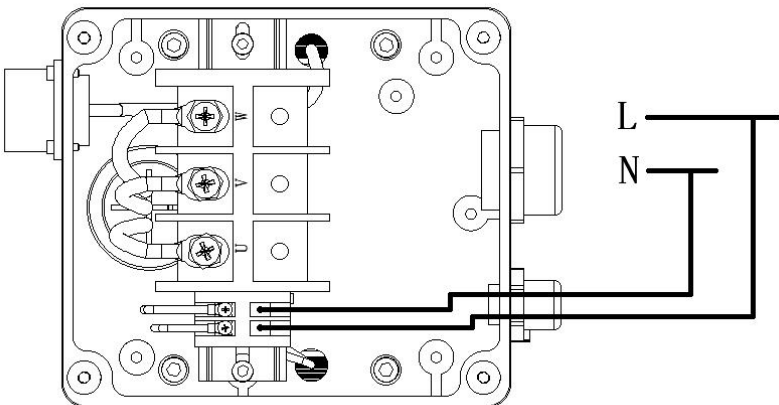

- The diagram above illustrates a wiring example for a motor fan, using the Xinje servo motor 200 chassis motor as an example.
- High-power air-cooled motors (11kW and above) are equipped with fans. The motor's internal structure must connect to both the power supply and fan power lines during factory assembly. Refer to the markings on the motor-fan connection point for the fan's voltage specifications.
- The fan's lead-out wire is pre-connected at the factory, and the other end can be directly plugged into the power supply through the fan outlet.

6.3.3 Fan Cooling Precautions

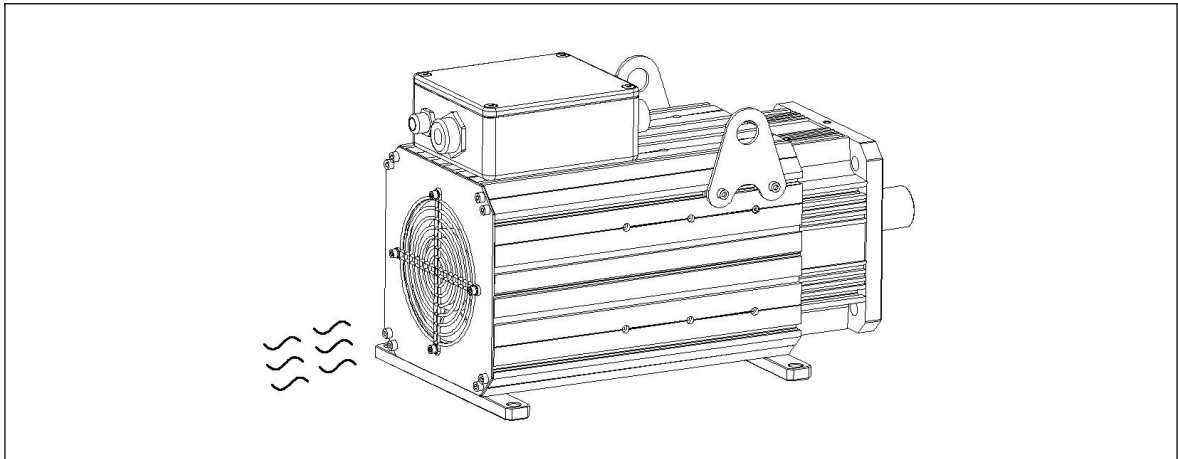

- For fan-equipped motors, ensure the air duct is unobstructed before installation, with a 30cm to 50cm clearance on the intake side.
- After connecting the fan, ensure it rotates normally and is in intake mode.
- The motor fan air ducts should be cleaned regularly based on actual usage conditions to prevent heat dissipation issues and prolong service life.
- Temperature sensors (NTC) are installed on the windings of motors with 200 or more stator seats, connected to pins 14 and 15 of the encoder's aviation plug. The real-time temperature of the servo motor windings is monitored by reading the driver parameters U0-98. If the motor triggers an E-061 alarm, check whether the motor fan is functioning properly.

7 fluid-cooled electrical machine

Specification of Common Liquid-cooled Motor			
Motor series	200 Chassis	265 Engine Base	360 Base
Standard flow rate of cooling medium (l/min)	> 12	> 24	> 40
Maximum allowable pipeline pressure (bar)	7		
Temperature range (°C)	5-45		
Cooling medium	1. Use a dedicated coolant (e.g., automotive coolant, 3M coolant PN3003, etc.). 2. A mixture of water and ethylene glycol in a 1:1 ratio. 3. A mixture of water and ionic neutralizers (e.g., ELF Chip Supra, Total 60L, Eurotherm Eurocold 131, etc.) is used as a coolant. Note: The right coolant prevents pipe blockage and corrosion, extending the machine's service life.		



- The water level in the cooling tank must be at least 100mm above the pump inlet.
- After a 5-minute shutdown, shut off the cooling medium to prevent condensation buildup inside the motor.
- The plug must be loosened and tightened manually with a wrench, as using an electric wrench may cause the plug to become fully locked.

Manual update log

Information about the revision of the data is recorded together with the data number in the lower right corner of the cover of this data.

Order number	Document ID	chapters and sections	Update content
1	MSC 01 20250319 1.0	-	First edition of the manual is published.
2	MSC 01 20250617 1.1	-	1. Optimize cable installation specifications; 2. Added 30-75kW fan specifications; 3. Some installation instructions are optimized.



XINJE

Wuxi Xinje Electric Co., Ltd.

WUXI XINJE ELECTRIC CO., LTD.

Address: No.816, West Jianzhu Road, Binhu District, Wuxi City, Jiangsu Province

General Office: 0510-85134136 Fax: 0510-85111290

Website: www.xinje.com Email: xinje@xinje.com

National Technical Service Hotline: [400-885-0136](tel:400-885-0136)